

AIRICOM

Ile de France
Paris et Nord

Votre interlocuteur

65 rue de la Libération - 60710 Chevrières
tél 03.44.91.04.14 - fax 03.44.91.04.15
www.airicom.com - info@airicom.com

AURECOM

Bretagne et
Grand Ouest

La Ville Cognac - 56430 Mauron
tél 02.97.22.79.72 - fax 02.97.22.90.51
www.aurecom.fr - info@aurecom.fr

RG2i

Rhône Alpes
Est et Sud-est

26 rue Bergson - 42000 Saint Etienne
tél 04.77.92.03.56 - fax 04.77.92.03.57
www.rg2i.com - info@rg2i.fr

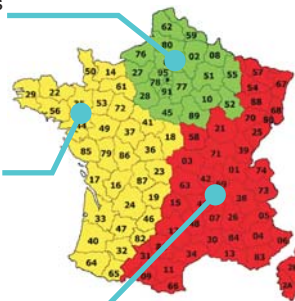

Groupe **PAR**

Wireless Solutions

RadioLinx[®] Wireless Products

ProLinx[®] Wireless Gateways

ProTalk[®] Wireless PLC Modules

inRAx[®] Wireless PLC Modules

The best choice in wireless.

Table of Contents

3

RadioLinx[®] Wireless Overview

4

RadioLinx Industrial Hotspots

5

RadioLinx Water Resistant Industrial Hotspots

6

RadioLinx Wireless FH Serial

7

RadioLinx Wireless FH Ethernet

8

ProLinx[®] High-Speed Wireless Gateways

- PROFIBUS
- EtherNet/IP

9

ProLinx High-Speed Wireless Gateways

- HART
- DF1
- Modbus
- Modbus TCP/IP
- ASCII
- IEC60870-5-104

10

inRAx[®] Wireless Ethernet ControlLogix[®] Module

11

Wireless Design & Site Survey Services

Why Choose ProSoft Technology[®] Wireless?

Communications are critical for industrial systems. ProSoft Technology's commitment to high performance wireless products backed up with automation system knowledgeable support, makes ProSoft the best choice for industrial wireless.

Automation and Wireless Technology Experts: ProSoft Technology's 20 years of protocol/application knowledge means wireless solutions that are designed to meet your application requirements. We understand all the nuances of industrial network and fieldbus protocols and can help you integrate your network successfully.

Security and Reliability: ProSoft Technology[®] wireless products offer the latest in security techniques and comprehensive diagnostic tools.

Industrial Grade: ProSoft Technology's wireless products are ideal for harsh environments, with industrial grade operating temperature, vibration, shock rating and a tough, metal enclosure that is DIN-rail mountable. Certifications include: cULus Class I Div 2 and ATEX Zone 2 for Europe. Class I, II, III Div 1 antenna fitting for explosion proof enclosures, and ATEX Zone I for the IH are also available.

Turnkey Solutions: Whatever your wireless network designs may be, ProSoft Technology provides a full line of products, accessories and technical expertise to assist you. Wireless engineering services such as computerized path planning analysis are also available.

Industry-leading Technical Support: ProSoft Technology's support team is dedicated to resolving your industrial communications challenges. On-line technical support is available 24 hours a day, 7 days a week. Our technical support staff located around the world in Asia, Europe, Latin America, Australia and North America are just a phone call away.





RadioLinx® Wireless

Industrial Hotspots

Ideal for high-speed Ethernet communications for industrial controllers, operator interfaces, video systems and wireless connectivity for mobile workers.

802.11abg Wireless Access Point/Repeater/Client

- Range up to 5 mi/8 km at 54 Mbps using OFDM modulation*
- Dual band (2.4 GHz & 5 GHz)
- WPA2 security
- Rugged metal enclosure

802.11abg Wireless IP65 Access Point/Repeater/Client

- Range up to 5 mi/8 km at 54 Mbps using OFDM modulation*
- Dual band (2.4 GHz & 5 GHz)
- WPA2 security
- IP65 water resistant metal enclosure

802.11b Wireless Access Point/Repeater/Client

- Range up to 20 mi/32 km at 11 Mbps using 2.4 GHz band*
- WPA security
- Rugged metal enclosure

Frequency Hopping Spread Spectrum

RadioLinx® frequency hopping radios offer reliable communications in crowded RF environments and outstanding security for SCADA systems.

Wireless FHSS Ethernet

- Range up to 15 mi/24 km using 2.4 GHz band*
- Ethernet 10/100 Base-T port

Wireless FHSS Ethernet with Serial Device Server

- Range up to 15 mi/24 km using 2.4 GHz band*
- 2.4 GHz frequency band
- Ethernet and serial port for serial encapsulation
- Modbus TCP/IP to Modbus serial connectivity

Wireless FHSS Serial

- Range up to 15 mi/24 km using 2.4 GHz band*
- Serial interface up to 115.2 Kbps
- Intelligent packet routing

*Actual distance may vary. Distance is dependent upon clear line-of-sight between antennas, antenna gain and antenna coax length. Local country regulations may limit range.

...the best choice in wireless.

Let ProSoft Technology's Experts Help Maximize Your Throughput



Understanding the throughput and latency requirements of industrial communications protocols and applications is a key part of selecting the correct wireless solutions. ProSoft Technology's automation and wireless application experts can help you...

- Determine required application data rate, impact of concentrating radios (repeaters or base stations) and select the correct wireless products
- Future-proof your wireless network by anticipating additional throughput requirements
- Be aware of adjustments that may be required for HMI/SCADA software to work correctly with wireless networks
- Design the wireless network to handle the significant number of packets-per-second resulting from multicast of producer-consumer type protocols, which may be the limiting factor vs. actual data rate
- Take advantage of fast wireless RF data rates vs. slower serial ports for larger messages with a low latency mode for serial modems
- Appreciate the unique wireless requirements of many industrial protocols
- Optimize wireless network design to minimize latency and maximize throughput

Optimize Plant Networks with OPC Wireless Diagnostics

Performance of wireless networks can change over time due to increased performance demands, changes in the RF environment and changes in the physical environment. Diagnostic tools are critical to maintaining an industrial wireless network.

Most industrial wireless systems support some form of diagnostics. Some provide only simple LED indicators while sophisticated systems offer online diagnostics capable of monitoring the entire wireless system, local and remote. While online diagnostic tools can be very useful, they often lack integration into the control system. This limits these tools to being reactive.

One approach to integrating diagnostic information into automation systems is using an OLE for Process Control (OPC) server. Because nearly all operator interface and SCADA software packages support OPC, the wireless diagnostic data is available to the HMI engineer just as any other data tag would be providing a flexible way to embed wireless network conditions into operator interfaces, alarm systems and trending software. Operator interface screens can include wireless link information tailored for the operator's technical level. It can also be used to monitor data traffic trends to better optimize plant network performance.

ProSoft Technology's RadioLinx[®] OPC Server reports diagnostic information from RadioLinx Industrial Hotspots and RadioLinx Frequency Hopping networks and is available as a no charge download.

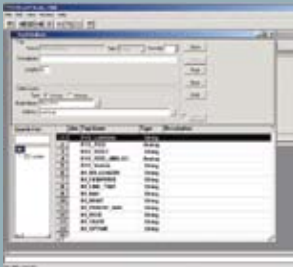

HMI Tag Browser Displaying the RadioLinx OPC Server Tags

RadioLinx[®] Industrial Hotspots

ProSoft Technology's line of Industrial Hotspots offer reliable, high speed wireless Ethernet communications based on the IEEE 802.11 standards. Designed specifically for industrial applications, Industrial Hotspots support both high speed Ethernet bridging and wireless infrastructure for portable network access.



All Industrial Hotspots include:

- Access Point, Repeater and Client modes (user selectable)
- Highly secure data encryption and authentication
- Self healing, mesh network architecture
- OPC wireless diagnostics server
- IGMP Snooping/Multicast Filtering for high performance EtherNet/IP systems
- Hazardous certifications for Class 1, Division 2 and ATEX Zone 2 installations (Class 1, Division 1 and ATEX Zone 1 solutions also available)
- IH Browser software for IP address management
- Embedded web server for configuration and diagnostics
- Extended operating temperature and high vibration/shock rating
- DC powered

Industrial Hotspot[™]

RLX-IH

802.11b Wireless Access Point/Repeater/Client

The RLX-IH is a high power, 802.11b solution for wireless Ethernet communications and plant network wireless access.

- Range up to 20 miles at 11 Mbps*
- WPA/TKIP encryption
- 10 to 24 VDC input power (AC wall mount adapter included)

* Distance values are subject to country regulations

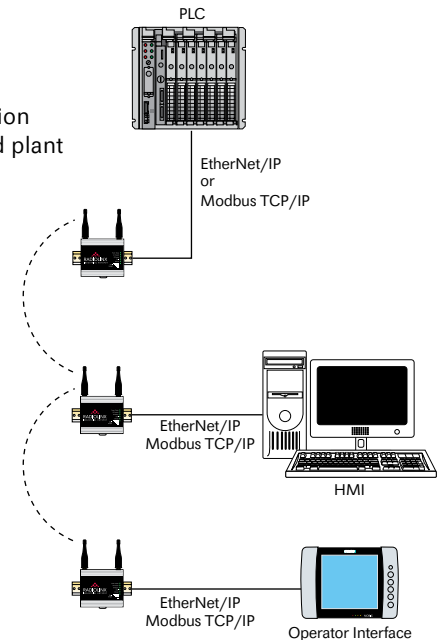

...the best choice in wireless.

Application Story



Reaching Hazardous Classified Sites with Wireless

Communicating to automation equipment in hazardous classified locations is challenging due to the high cable installation cost. Wireless provides a much more cost effective solution. However the wireless hardware must have the proper certifications.

Sites that are classified as Class 1, Division 2 or ATEX Zone 2 require that hardware installed carry these certifications or must be housed in a certified enclosure. Low power spread spectrum RF antennas may be mounted in these sites as long as they connect to a certified wireless modem or access point.

Regulations for Class 1, Division 1 or ATEX Zone 1 have much stricter requirements as explosive materials are normally present. Explosion proof or purged enclosures are often required for all electrical hardware. This presents a particular problem for wireless systems as the antenna must be externally mounted to provide reliable communication.

One option for wireless communications in Class 1, Division 1 or ATEX Zone 1 sites is to use an approved, intrinsically safe antenna coupler to connect the wireless modem inside the explosion proof enclosure to the external antenna. This provides a fully certified hazardous solution while optimizing wireless communication performance.

Many OEMs and end users in the oil, gas, mining, waste management, pharmaceutical and agricultural industries rely on ProSoft Technology's wireless solutions for hazardous site communications.

Industrial Hotspot™ RLX-IHW 802.11abg Wireless Access Point/Repeater/Client

Designed for global installations, the RLX-IHW offers high speed wireless Ethernet communications for linking automation systems, Ethernet I/O, video cameras and plant network access for mobile workers. It is an ideal solution for demanding, high speed networks where RF multicast packet filtering and dual frequency bands ensure reliable performance.

- OFDM modulation for excellent noise immunity at highest possible speeds
- Range up to 5 mi/8km at 54 Mbps (farther with optional amplifier)*
- Dual frequency band (2.4 GHz & 5 GHz)
- WPA2 (802.11i) AES encryption for high security
- Programmable RF power output to meet regional regulations
- Rugged metal enclosure
- 10 to 24 VDC input power (AC wall mount adapter included)

* Distance values are subject to country regulations

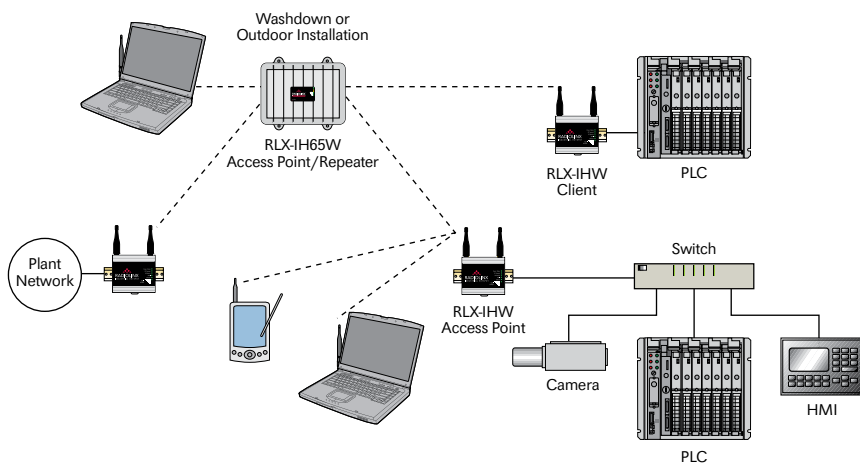

Industrial Hotspot™ RLX-IH65W 802.11abg Water Resistant Access Point/Repeater/Client

The RLX-IH65W includes all the features of the RLX-IHW in an IP65 rated, water resistant enclosure. Its water resistant enclosure permits it to be directly installed in wash down areas or outdoors simplifying installation. The RLX-IH65 may be installed next to the antenna thus reducing antenna coax attenuation and maximizing range. Power over Ethernet (PoE) provides an easy way to remotely power the access point.



Choosing the Right Antenna

ProSoft Technology[®] gives you the power to choose the optimal antenna combinations for your application. For a complete list of antennas and accessories available visit www.prosoft-technology.com.

Omni Directional Antennas

Designed to receive and transmit radio waves in all directions (360 degrees).



Whip and Articulating Whip

The whip antenna works well with remote radios. The articulating whip antenna bends at the connection and is typically connected to a remote radio.



Omni Directional Collinear

Provides maximum performance, higher gains and reliability under the toughest weather conditions. Choose from mast, wall or ceiling mounted. Allows outdoor installation in harsh climates.

RadioLinx[®] Frequency Hopping Series

Frequency hopping offers long range communications and outstanding immunity to EMI/RFI. Ethernet, serial and combined Ethernet/Serial models are available.

All RadioLinx[®] frequency hopping modems include:

- 2.4 GHz band for license-free communications
- Communications up to 15 mi/24 km* at an RF data rate of 250 Kbps
- Repeater mode with support for one or two active antennas
- True peer-to-peer packet routing regardless of RF architecture
- Hazardous certifications for Class 1, Division 2 and ATEX Zone 2 installations (Class 1, Division 1 and ATEX Zone 1 solutions also available)



ControlScape Configuration and Diagnostic Software

ControlScape software provides easy RadioLinx configuration and network diagnostics. The RadioLinx OPC Diagnostic Server (page 4) is also available for embedding diagnostic information into OPC clients such as HMI and SCADA software.

Diagnostic tools allow you to troubleshoot remotely.



Wireless FH Serial RLX-FHS

RadioLinx Frequency Hopping Serial radios are ideal for providing peer-to-peer and store-and-forward to devices with traditional, master/slave protocols.

- RS232/422/485 configurable interface up to 115.2 Kbps
- Peer-to-peer packet routing for DF1, ModBus and DNP 3.0 protocols
- Supports multiple protocols over the same RF network

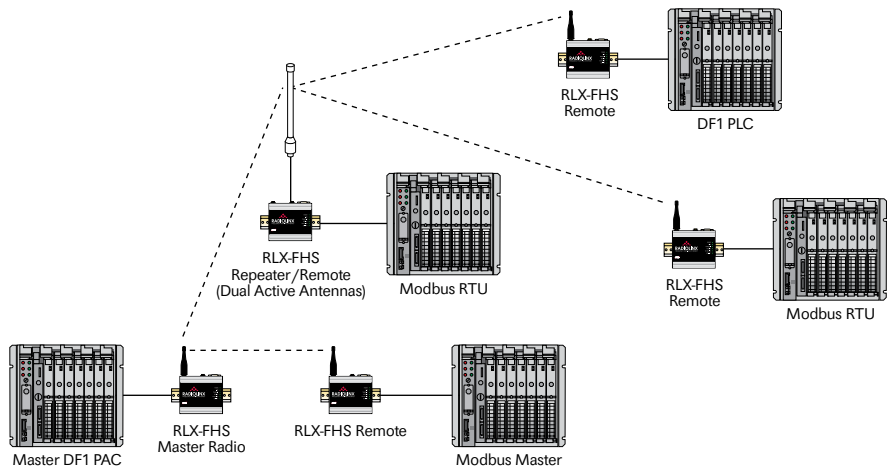



Wireless FH Ethernet RLX-FHE

Radiolinx® Frequency Hopping Ethernet radios are the ideal solution for secure, long-range SCADA communications and in tough, noisy environments where reliability is more important than speed.

- Ethernet speeds up to 100 Kbps
- Proprietary frequency hopping and 128 bit encryption for excellent noise immunity and security
- Compatible with all Ethernet protocols including TCP/IP, UDP/IP, Modbus TCP/IP, EtherNet/IP and HTTP

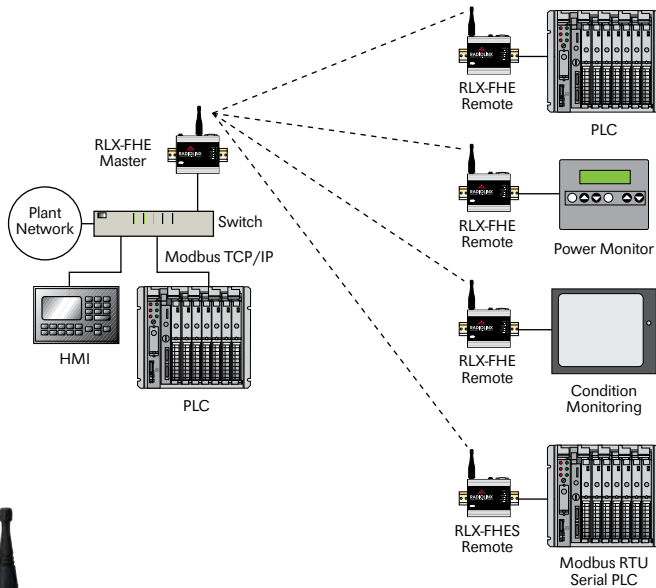

Wireless FH Ethernet with Serial Device Server RLX-FHES

The RLX-FHES offers all the capabilities of the RLX-FHE with a serial device server for transmitting serial protocols over the wireless Ethernet network.

Applications include serial encapsulation and connection of Modbus RTU serial devices to wireless Modbus TCP/IP networks.

- Enables serial device communication over Ethernet using port-redirect software
- Connects Modbus RTU serial devices to Modbus TCP/IP wireless Ethernet networks
- Supports Modbus RTU, Modbus ASCII, DNP 3.0., DF1, ASCII and other ASCII based serial protocols

Choosing the Right Antenna

Directional Antennas

Directional antennas transmit and receive radio waves from the direction they are aimed.



Yagi

Directional Yagi antennas can be used as bridge antennas between two networks or for point-to-point communications. Field adjustable to allow vertical or horizontal polarity. Eliminates co-channel interference from neighboring radiators.



Panel/Patch

Panel antennas are designed to obtain maximum gain with an attractive, low profile package. All models provide efficient and stable performance across the band and can be mounted indoors and outdoors.

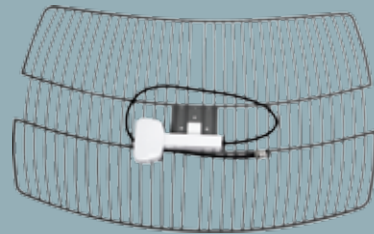

Parabolic

Parabolic antennas are constructed of high-grade magnesium alloy material which is lightweight, does not rust, and is durable enough to survive changing climate conditions. The grid reflector design provides field reliability and ease of handling and installation.

In-chassis Wireless for Quantum



ProTalk[®]

The new in-chassis ProTalk[®] wireless interface modules provide users more flexibility than ever before in wireless solutions. Users can connect various field devices using different networks or protocols and share data between these devices wirelessly via ProSoft Technology's efficient and powerful wireless protocol, ProSoft Wireless Protocol (PWP). Network protocols are converted into common "radio packets" (PWP) allowing messages to be transmitted to any 802.11b radio connected to the network.

ProSoft Wireless Protocol (PWP). Network protocols are converted into common "radio packets" (PWP) allowing messages to be transmitted to any 802.11b radio connected to the network.

ProLinX[®]

High-Speed Wireless Gateways

The ProLinX[®] 6000 series of wireless gateways provide users more flexibility than ever before in wireless solutions. Users can connect various field devices using different networks or protocols and share data between these devices "over-the-air." This is accomplished by exchanging shared common database information wirelessly with ProSoft Technology's efficient, but powerful wireless protocol, PWP.



6104-WA-PDPM

6105-WA-PDPS

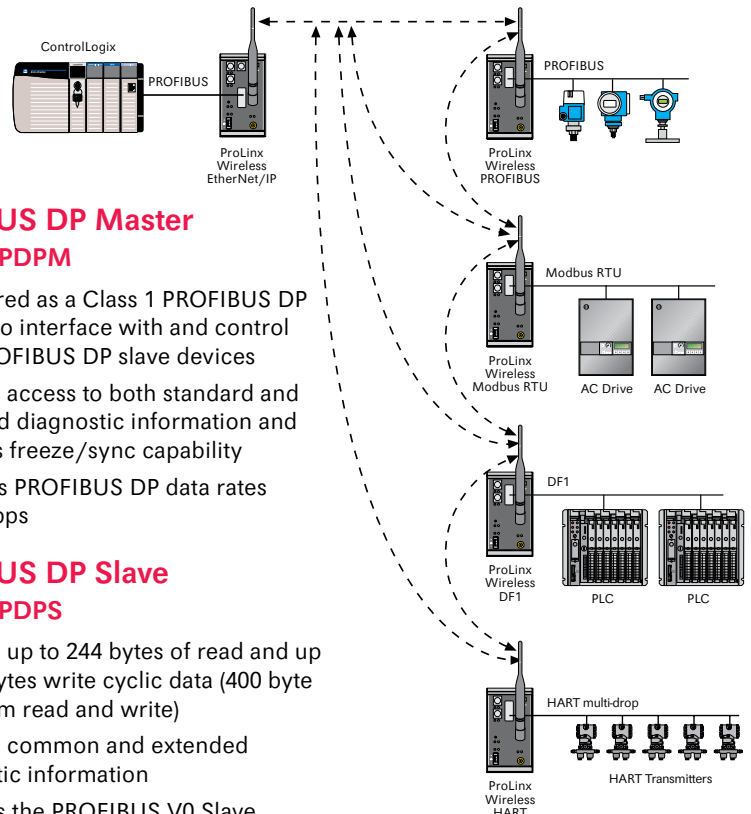

PROFIBUS DP Master
6104-WA-PDPM

- Configured as a Class 1 PROFIBUS DP Master to interface with and control your PROFIBUS DP slave devices
- Provides access to both standard and extended diagnostic information and provides freeze/sync capability
- Supports PROFIBUS DP data rates to 12 Mbps

PROFIBUS DP Slave
6105-WA-PDPS

- Provides up to 244 bytes of read and up to 244 bytes write cyclic data (400 byte maximum read and write)
- Provides common and extended diagnostic information
- Supports the PROFIBUS V0 Slave implementation protocol

EtherNet/IP
6201-WA-DFNT

- Supports Explicit Messaging
- User-configurable as both a Client and a Server

DF1 Master/Slave
6201-WA-DFCM

- Full/Half Duplex
- Up to 100 commands per Master port, each fully-configurable
- User-configurable polling of commands, including disabled, continuous, and on change of data

Modbus Master/Slave
6201-WA-MCM

- Supports both Master and Slave implementations
- Serial ports can be individually configured to support the Modbus protocol
- Up to 100 commands per port

Modbus TCP/IP
6201-WA-MNET

- Supports Client and Server connections
- Supports Unicast, Broadcast and Multicast group messaging

ASCII
6201-WA-ASCII

- Each port is configurable to send and/or receive ASCII strings
- Integrates ASCII generic serial devices into a network

IEC 60870-5-104
6201-WA-104S

- Accepts commands from Master and generates unsolicited messages

HART Multi-drop
6207-WA-HART-4 HART channels
6227-WA-HART-8 HART channels

- Available in 4 and 8 channel implementations
- Can be configured on an individual channel basis to operate as a HART Master Station
- Supports all available HART commands including Universal, Common Practice and Device Specific commands
- Communicate in multi-drop mode with up to 15 HART devices per channel

What Can ProSoft's Wireless Protocol Do For You?

Provide cost-saving wireless links to industrial devices regardless of communications protocols.

Connect your EtherNet/IP network to end devices regardless of protocol

Connect devices using many protocols to a common protocol, such as EtherNet/IP or Modbus TCP/IP.

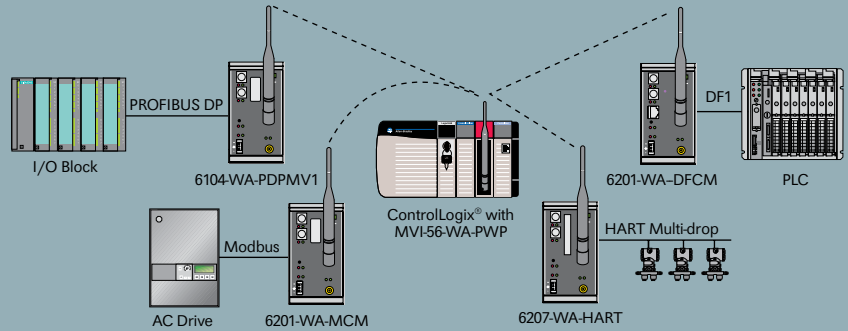

Wireless connectivity for field protocols

Allow wireless communications for PROFIBUS DP, HART, and other devices using protocols that are not supported by standard radios.

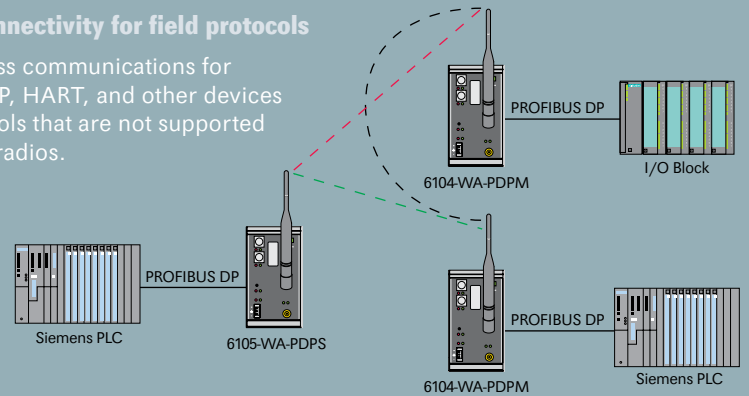

Support redundant controllers

Support redundant controllers through flexible wireless multicasts.

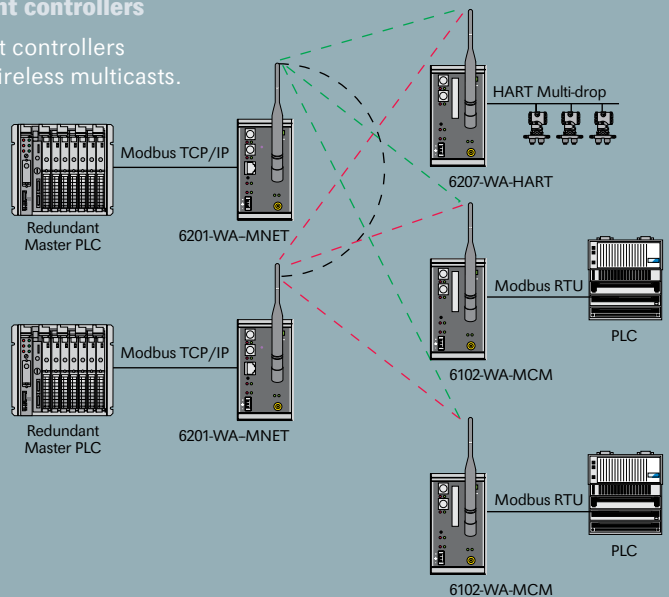

Application Story



Avoiding Collisions

In 2006, Andritz Inc. was commissioned for a nearby project requiring the supply and installation of two Portal Cranes which would be used for unloading lumber from trucks and transporting the materials to an onsite woodyard. The cranes would need the ability to operate independently and simultaneously along the overhead rail of the gantry. Given the needs of the application, the standard practice of using 300 foot-long bus bars or festooning cables to communicate between the gantry and trolley was not an option since bus bars can only communicate from gantry-to-crane and not crane-to-crane, so crane collision accidents still pose a huge threat and cost factor.

Andritz placed a GPS system on each crane to accurately determine their respective locations on the rail. For this to be an effective solution, the positioning of each crane would have to be accessible to all control rooms and between the cranes, Andritz selected ProSoft Technology® RadioLinx® Frequency Hopping Ethernet Switches (RLX-FHES) as their wireless solution.

Now there is an anti-collision system capable of automatically slowing the two cranes to a stop should they enter a predetermined collision zone, thus preventing impact.

“The main advantage of using ProSoft’s high-speed Ethernet radio systems is that they help the cranes avoid collisions on both the network and on the track,” said Robert Dunlop, System Integrator for Andritz. “Plus, operating wirelessly creates a significant cost savings by eliminating bus bars and festooning cables.”

inRAx®

In-rack Wireless

Wireless EtherNet/IP for ControlLogix® MVI-56-WA-EIP

- Wirelessly connects Wi-Fi laptops and PDAs to ControlLogix backplane
- Supports FactoryTalk®, RSLogix™ 5000, RSLinx®, RSVIEW®, and RSNetworx™ applications
- No need to open cabinet or panel to program
- Wireless network is isolated from plant/business wired network
- Connects ControlLogix to Plant Network via Wi-Fi access point
- No Ethernet module or switch required
- Wirelessly program and configure devices on other PLC networks including DH+, ControlNet, EtherNet/IP and DeviceNet

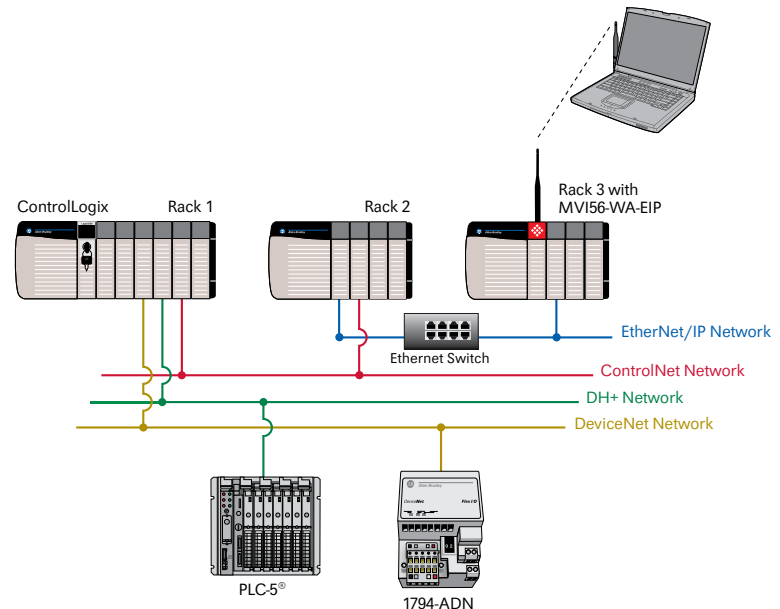

Technical Support for Planning and Implementing Wireless Networks

ProSoft Technology® provides various levels of technical support and application assistance to ensure the success of wireless applications. Applications may vary in complexity, from a pair of radios communicating across a factory floor to hundreds of radios spread over a large metropolitan area.

Defining the Application

ProSoft Technology Wireless Application Engineers can help you define your application. Support is paramount with any wireless product. Our Application Engineers are experienced in the industry and are familiar with automation applications, specific industry protocols and networking, and radio path engineering.

Path Planning and On-site Services

Path planning is an essential part of an outdoor wireless solution providing an accurate account of items and budgetary costs required for the project. ProSoft Technology can provide assistance for generating a Path Planning Report. A Path Planning Report includes a complete wireless bill-of-materials, antenna type, gain, height, tilt angle and location requirements, calculated fade margins, and a graphical path profile for each site and network topological terrain map. The report will also assist systems integrators with initial design specifications for testing and verifying each path link. In order to produce the report, a Site Audit is required by the end user or engineering firm. A Site Audit collects GPS, obstruction and existing structure data. This data supplies the Wireless Application Engineer pertinent information to provide a summary report for each site and path. In many cases a Site Survey is then performed to verify the report findings and analyze RF noise conditions. Often Path Planning Reports are available at no additional cost. However, path planning reports for large systems, Site Audit and Site Survey services do require a fee. Contact ProSoft Technology for more information.

Request for Quotation

ProSoft Technology takes pride in providing our customers with an accurate and detailed quotation. Contact your sales representative for more information.

Please contact your local ProSoft Technology Wireless Distributor for site survey assistance.

ProSoft Tested



In order to ensure confidence and success with the use of our products, we have implemented the ProSoft Tested Program. Devices which are thought to be compatible with ProSoft Technology® products have been extensively tested so that we can provide the performance information you need to make confident purchasing decisions for your automation applications. This program provides:

- Proven connections
- Simulation of field applications
- Detailed test reports
- All protocol commands tested
- All accessory requirements listed
- Various configurations tested
- All reports available on the website

Know with confidence that your application will work. The listing below is a partial list of products that are known to be ProSoft Technology compatible. For a complete list go to www.prosoft-technology.com. If you would like your application tested, simply contact ProSoft Technology and ask for the ProSoft Tested Program. We'll arrange for your product to be tested at no charge to you.

Bar Code Scanners	Loop Controllers
Chart Recorders	PLC Manufacturers
Drives	Power Devices
Flow Devices	Valves
Level Interfaces	
Temperature Controllers	



Where Automation Connects.



About ProSoft Technology®

ProSoft Technology, Inc. specializes in the development of communication solutions compatible with supplier's controllers such as Rockwell Automation® and Schneider Electric. The primary focus is to provide connectivity solutions that link dissimilar automation products. ProSoft Technology's offerings consist of four primary product families: Protocol and network connectivity modules known as **inRAx**® for Rockwell Automation and **ProTalk**® for Schneider Electric, stand-alone gateways, protocol interfaces, and wireless gateways known as **ProLinx**®, and industrial serial and Ethernet wireless modules known as **RadioLinx**®.

Over the last 20 years, ProSoft Technology's product lines have grown to over 400 communication modules supporting more than 60 different protocols. ProSoft Technology provides field-proven connectivity and communication solutions that bridge between various automation products as seamlessly as if they were all from the same supplier. These connectivity options enable controller platforms to provide solutions in areas such as computing gas flow calculations and SCADA telemetry applications. These solutions also enable interfacing to motor controls, drives and other devices in industries such as water/wastewater, power generation, oil & gas, machinery, packaging, and production.

ProSoft Technology is committed to providing localized sales and support to customers worldwide. Sales, product engineering and support services are provided internationally by over 500 distributors in 52 countries and served by Regional Area Offices in North America, Latin America, Europe and Asia Pacific.

**Please call the Area office
in your region and they will
direct you to the nearest sales
representative.**

Asia Pacific

+603.7724.2080
asiapc@prosoft-technology.com

Europe

+33 (0)5.34.36.87.20
europe@prosoft-technology.com

Latin America

+1 281.298.9109
latinam@prosoft-technology.com

North America

+1 661.716.5100
Fax: +1 661.716.5101
info@prosoft-technology.com